



The C7339 Position Sensor is an opto-electric position-sensing unit which measures the position of a single point of light spot-focused onto the sensor head.

The use of hybrid circuitry allows for a compact, light-weight design and a divided configuration with a light, compact sensor head and a controller equipped with a light level indicator and data displays for ease of operation. The measured position is displayed digitally in terms of X- and Y-coordinate voltages on the front panel of the controller and may be simultaneously output to a recorder.

The C7339 does not possess a background-light cancellation function and is suited for use in locations where the signal light is distinct from the background such as in the detection of laser beams.

SYSTEM CONFIGURATION EXAMPLE

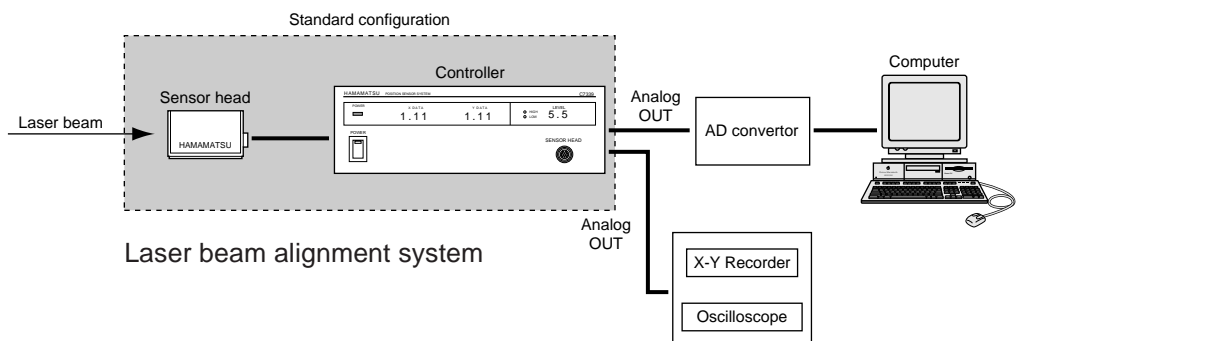

FEATURES

- **Quick Response**
The response time of less than $20\mu\text{s}$ enables accurate measurement of the spot, even while it is moving at high speeds.
- **Stable Measurement**
The position data (X-Y coordinate voltages) of a light spot is obtained without being affected by signal current fluctuations from the PSD, enabling accurate position measurement regardless of fluctuations in the light intensity.
- **Broad Spectral Response**
The C7339 has a broad spectral range, from 300 to 1100 nm, enabling the detection of a variety of light sources, including lasers.
- **High Resolution**
The PSD employed in the sensor head is of the non-discrete type, which, contrary to a discrete-type sensor, has no insensitive area. This enables continuous measurement at a high resolution of 1/5000 (when using a recorder).
- **Light Level Indicator**
The input light level is indicated in digits on the front panel of the control unit (0.00 to 10.0) so as to make it easy to adjust the lens iris and select an ND filter.

OTHER APPLICATIONS

- Surface Flatness Measurement
- Solar Tracking Systems

CONFIGURATION

Sensor head (C7339-01)	1
Controller (C7339-0X*)	1
AC cable (2m)	1
Head connecting cable (5m)	1
Signal cables (BNC-BNC, 3m)	2
Fuses (1A)	3
Line voltage * X = 2	100V
3	117V
4	220V
5	240V

OPTIONAL

Metal interference filters
Filter adapter

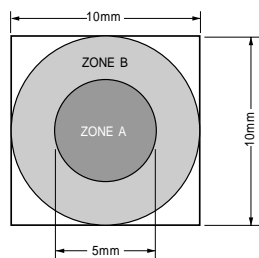

Fig.1 Useful Sensitive Area and Zones A and B

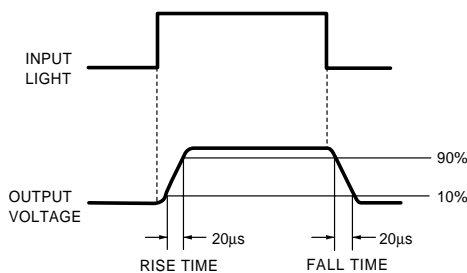

Fig.2 Rise and fall time of the output voltage when a pulsed light is applied to the center of the sensitive area.
The rise time is the period of time required for the output voltage to rise from 10% to 90% of its full level.
The fall time is the period required for the output voltage to return from 90% to 10%.

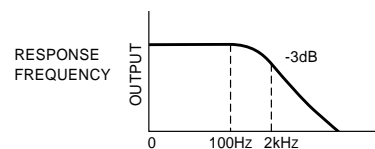

Fig.3 Response frequency of the output voltage when a spot light is moved right and left repeatedly while it is being applied to the sensitive area.

SPECIFICATIONS

Detector	Non-discrete position-sensitive detector (Hamamatsu S1880-03)
Useful sensitive area (Fig.1)	10 × 10mm
Lens mount	C mount
Output voltage: X-axis	- 5 to + 5V
Y-axis	- 5 to + 5V
Output impedance	500Ω ± 10%
Response speed (Fig.2)	Within 20µs
Recommended measurement light level	Light level (Σ) = 8 (Displayed on a level indicator)
Position detection error	Zone A (refer to figure below) ±1.0%, Zone B ±2.0%
Error due to light intensity variations	±1% (Light level (Σ) = 8→4)
Resolution (when using a recorder)	1/5000
Jitter	±1.5/1000
Drift	±0.5%/day (after the first 30 minutes)
Operating temperature	0 to +40°C
Storage temperature	-10 to +50°C
Operating/storage humidity	Less than 90% (with no condensation)
Line voltage	100/117/220/240VAC ±10%, 50/60Hz
Power consumption	Approx. 30VA

OPTIMUM INPUT LASER POWER

Laser	Wavelength	Input Laser Power
He-Ne Laser	632nm	Approx. 23µW
Ar Laser	514nm	Approx. 27µW

When light with the value on the table at the left is input, "8" appears on the display indicating the volume of incident light. If strong laser light is used, an ND filter or similar means should be used to reduce the volume of laser light to the optimum volume before beginning measurement.

DIMENSIONAL OUTLINE (UNIT:mm)

- Sensor head (Weight: Approx. 140g)

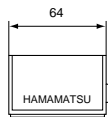
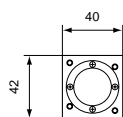

- Controller (Weight: Approx. 3.87kg)

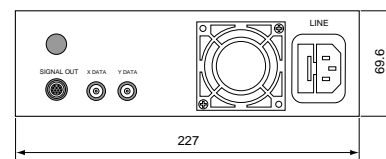
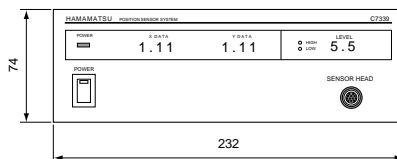

- Subject to local technical requirements and regulations, availability of products included in this promotional material may vary. Please consult with our sales office.
- Information furnished by HAMAMATSU is believed to be reliable. However, no responsibility is assumed for possible inaccuracies or omissions. Specifications and external appearance are subject to change without notice.

© 1999 Hamamatsu Photonics K.K.



HAMAMATSU

HAMAMATSU PHOTONICS K.K., Systems Division
812 Joko-cho, Hamamatsu City, 431-3196, Japan, Telephone: (81)53-431-0124, Fax: (81)53-435-1574, E-mail:export@sys.hpk.co.jp

U.S.A. and Canada: Hamamatsu Photonic Systems: 360 Foothill Road, Bridgewater, N.J. 08807-0910, U.S.A., Telephone: (1)908-231-1116, Fax: (1)908-231-0852
Germany: Hamamatsu Photonics Deutschland GmbH: Arzbergerstr. 10, D-82211 Herrsching am Ammersee, Germany, Telephone: (49)8152-375-0, Fax: (49)8152-2658
France: Hamamatsu Photonics France S.A.R.L.: 8, Rue du Saule Trapu, Parc du Moulin de Massy, 91882 Massy Cedex, France, Telephone: (33)1 69 53 71 00, Fax: (33)1 69 53 71 10
United Kingdom: Hamamatsu Photonics UK Limited: Lough Point, 2 Gladbeck Way, Windmill Hill, Enfield, Middlesex EN2 7JA, United Kingdom, Telephone: (44)181-367-3560, Fax: (44)181-367-6384
North Europe: Hamamatsu Photonics Norden AB: Smidesvägen 12, SE-171-41 Soina, Sweden, Telephone: (46)8-509-031-00, Fax: (46)8-509-031-01
Italy: Hamamatsu Photonics Italia S.R.L.: Strada della Moia, 1/E 20020 Arese (Milano), Italy, Telephone: (39)02-935 81 733, Fax: (39)02-935 81 741

Homepage Address <http://www.hamamatsu.com>

Cat. No. SIMS1004E01
FEB/99 CR
Created in Japan (PDF)